

**Specification Data**  
**Column & Boom Manipulators**  
**RM Pipe Shop Series**  
**Range up to 2.0 x 2.0 metres**

The **A&N** RM series of Column & Boom Manipulators are specifically designed and built to withstand the harsh and rugged environments expected in the welding industry. It includes the following features:

- A slewing ring for column mounting, thereby providing a smooth 360-degree lockable rotation.
- All vertical and horizontal rails are precisely machined in single runs giving unsurpassed smooth and steady travel.
- Latest Inverter drives fitted for variable speed of horizontal boom arm travel.
- Worm gearbox for vertical travel via AC motor complete with brake for added safety.
- IP 55 control box and low voltage pendant control station (motorised boom only).
- Standard safety feature includes limit switches for all functions.
- Internally trunked cabling.

Inclusive:

- Fitted with manual travel car for rail mounting

**Optional features includes**

- X-Y slide, manual or motorized.
- Compressed air operated flux recovery unit
- Welding power source & wire feeder controller system

All **A&N** Column & Boom Manipulators are grit blasted to SA2.5 and two coats of zinc phosphate paint followed by one coat of polyurethane paintwork will ensure that your investment provides you with many years of uninterrupted service.

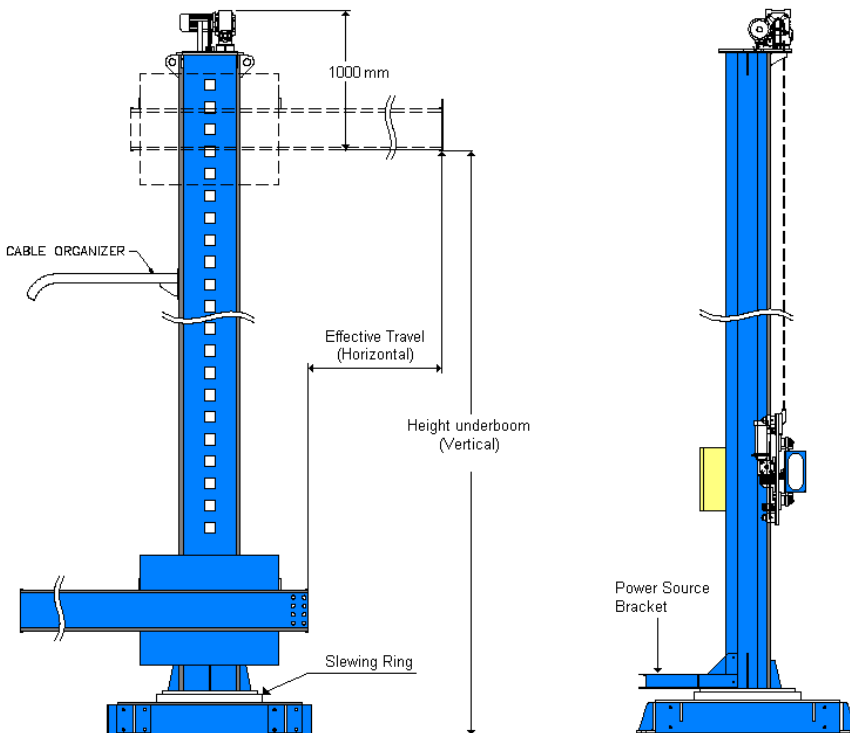

..... [www.anplant.com](http://www.anplant.com) .....

## Specification

Input Voltage: 3-Phase Voltage (Specify 3 –phase voltage requirement before ordering)			
Electrical Box: IP55 code			
Vertical Travel Speed: 600mm/min			
Boom Travel Speed: 248 to 2480 mm/min			
Model	Effective Travel (Horizontal) mm	Height Under Boom (Vertical) mm	Overall Height (mm)
RM1812 VLS-TCC	1200	1800	2616

### Ordering Information Checklist

Equipment	Part Number	Description	
Column & Boom Manipulator	RM1812VLS	1.8 x 1.2 VLS-TCC Pipe Shop Manipulator	
Base	TC-	Travel Car Manual	Standard
Electrical Control	EA-SA-	Panel & 3-phase AC motor Panel, step-over & 3-phase AC motor	Standard Optional

### Welding System Accessories

<p><b>Option One</b></p> <ul style="list-style-type: none"> <li>• Lincoln NA3s Controller</li> <li>• K208A weld head</li> <li>• Drive roll kit</li> <li>• Wire reel</li> <li>• 600 amps nozzle</li> <li>• Cable kit Assemble</li> <li>• 10-Metre ground Cable with clamp</li> <li>• DC 1000 power source</li> </ul> <p><b>Optional:</b></p> <p style="padding-left: 40px;">Rotary Clamp 1000 amp</p>	<p><b>Option Two</b></p> <ul style="list-style-type: none"> <li>• Lincoln NA5 Controller</li> <li>• K346A weld head</li> <li>• Drive roll kit</li> <li>• Wire reel</li> <li>• 600 amps nozzle</li> <li>• Cable kit Assemble</li> <li>• 10 Metre ground Cable with clamp</li> <li>• DC 1000 power source</li> </ul> <p><b>Optional:</b></p> <p style="padding-left: 40px;">Rotary Clamp 1000 amp</p>	<p><b>Option Three</b></p> <ul style="list-style-type: none"> <li>• Miller HDC 1500 Controller</li> <li>• RAD Weld head</li> <li>• Flux hopper</li> <li>• Drive roll kit (Specify wire size)</li> <li>• Wire straightener</li> <li>• 600amps Nozzle</li> <li>• Wire reel</li> <li>• Cable kit assembly</li> <li>• 10 Metre ground Cable with clamp</li> <li>• Dimension 1000 power source</li> </ul> <p><b>Optional:</b></p> <p style="padding-left: 40px;">Rotary Clamp 100 amp</p>
--	---	--

..... [www.anplant.com](http://www.anplant.com) .....

### Specification for Manipulator

1	Model	RM1812VLS-TCC-EA-C1040
2	Vertical Speed	600 mm/min 0.37kW at 50Hz
3	Boom Speed	248 to 2480mm/min 0.37KW at 5 to 50Hz
4	Travel Speed	N.A.
5	Max. Under Boom Height	1800 mm
6	Effective Boom Travel	1200 mm
7	Welding Control/ Brand	Lincoln NA-3S
8	Welding Power Source/ Brand	Lincoln DC 1000 (By Client)
9	Electrical Panel	Yes
10	Base Type	Push-Type Travelcar
11	Travelcar C-C	1040mm
12	Slewing Feature	Yes, Manual
13	Power Supply	415V-3P-50Hz
14	Control Voltage	24VAC
15	Control Means	Via push button pendant on 6m cable
16	Surface Preparation	Gritblast to SA2.5
17	Painting	2 coats Zinc Phosphate, 1 coat Polyurethane
18	Color	RAL5015 Blue
19	Qty	2 units

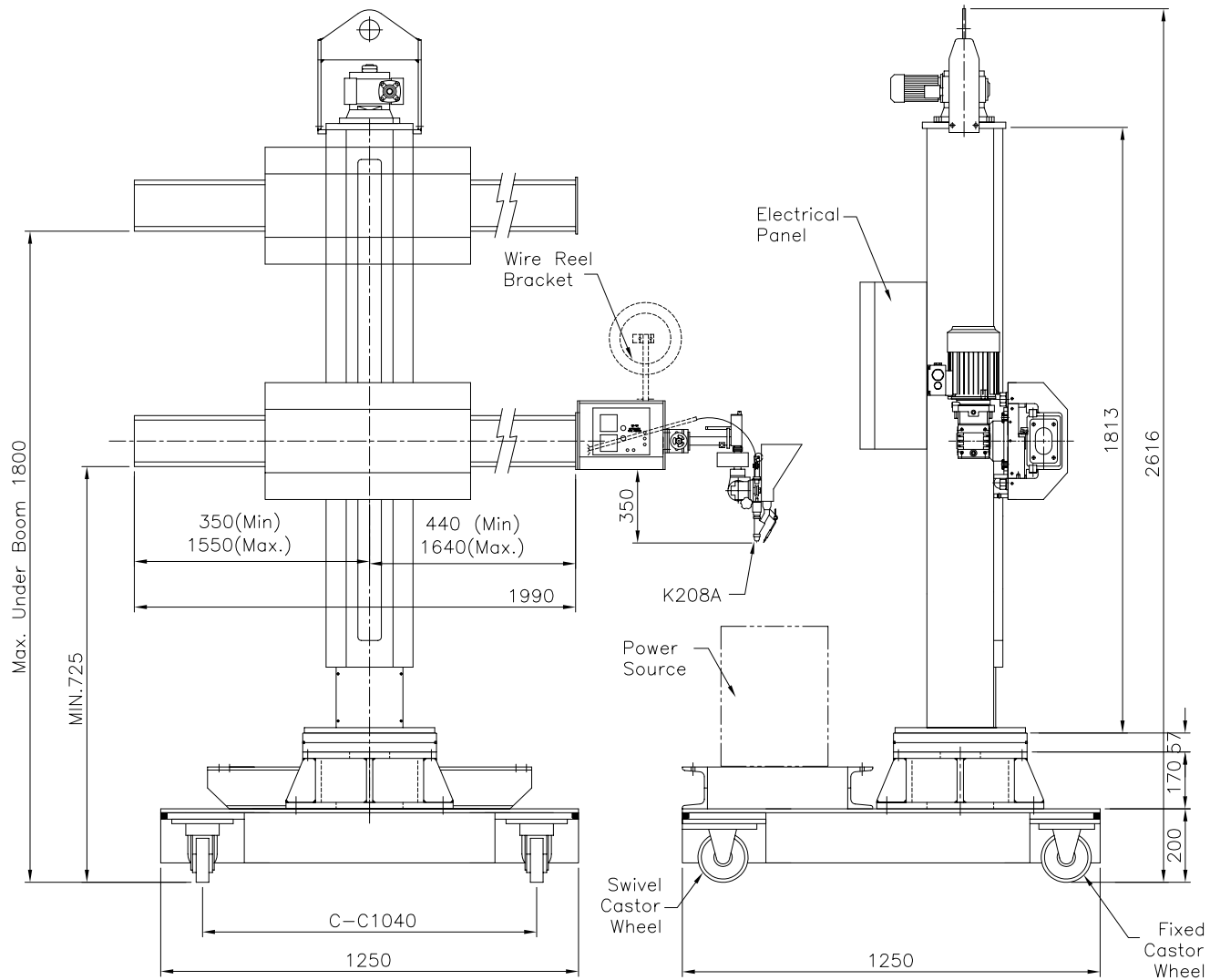

ALL DIMENSIONS IN MM UNLESS OTHERWISE SPECIFIED.

 <b>A&amp;N PLANT</b> <small>ROTATORS - COLUMN BOOMS - POSITIONERS</small>		PROJECT/MODEL : <b>RM1812VLS-TCC-EA-C1040</b>	
DRAWN : NAME : Kris DATE : 25-05-06		CLIENT :	
APPROVED :		DWG. NAME : Manipulator General Arrangement	
		DWG. NO. :	
		SCALE: N.T.S. REVISION: 1 SHEET NO: 1 OF 1	
THE ORIGINAL AND ALL COPIES OF THIS DRAWING TOGETHER WITH THE COPYRIGHT THEREOF ARE THE SOLE PROPERTY OF R.P.E. PTE. LTD. SINGAPORE			