

**Specification Data**  
**Column & Boom Manipulators**  
**MHD Series**  
**Range up to 4.0 x 4.0 metres**

The **A&N** MHD series of Column & Boom Manipulators are specifically designed and built to withstand the harsh and rugged environments expected in the welding industry. It includes the following features:

- A slewing ring for column mounting, thereby providing a smooth 360-degree lockable rotation.
- All vertical and horizontal rails are precisely machined in single runs giving unsurpassed smooth and steady travel.
- Latest Inverter drives fitted for variable speed of horizontal boom arm travel and rail travel car (optional).
- Worm gearbox for vertical travel via AC motor complete with brake for added safety.
- High tensile roller chain used for vertical travel with the addition of a counter balance system provides smooth effortless vertical travel.
- IP 55 control box and low voltage pendant control station.
- Standard safety feature includes anti-fall device and limit switches for all functions.
- Internally trunked cabling.

Inclusive:

- Power source mounting bracket of your choice

**Optional features includes**

- Travel car, manual or motorized variable speed operated via the same pendant station via selector switch.
- X-Y slide, manual or motorized, operated via the same pendant station.
- Compressed air operated flux recovery unit
- Welding power source & wire feeder controller system

All **A&N** Column & Boom Manipulators are grit blasted to SA2.5 and two coats of zinc phosphate paint followed by one coat of polyurethane paintwork will ensure that your investment provides you with many years of uninterrupted service.

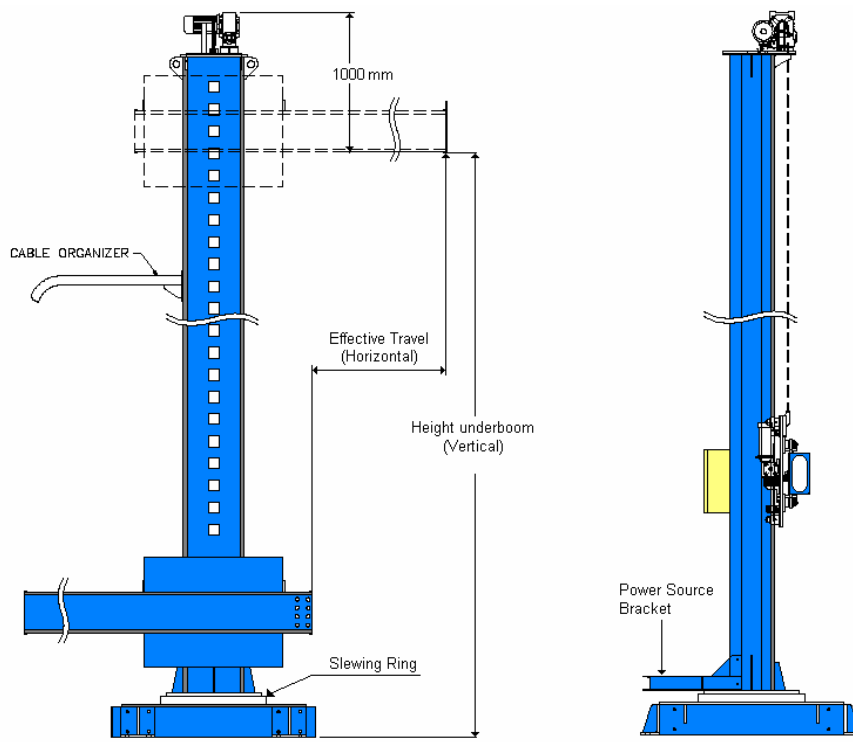

MHD Series (Up to 4.0 x 4.0m) (C&B)

## Specification

Input Voltage: 3-Phase Voltage (Specify 3 –phase voltage requirement before ordering)

Electrical Box: IP55 code

Vertical Travel Speed: 750mm/min

Boom Travel Speed: 200 to 2070 mm/min

Carriage Travel Speed: 450 to 4500 mm/min (optional)

Model	Effective Travel (Horizontal) mm	Height Under Boom (Vertical) mm	Overall Height (mm)
RM2525 MHD	2500	2500	3500
RM3030 MHD	3000	3000	4000
RM3535 MHD	3500	3500	4500
RM4040 MHD	4000	4000	5000

All dimensions are subject to change without prior notice.

All speed base on 50Hz.

Please advise welding power source/welding head to be use.

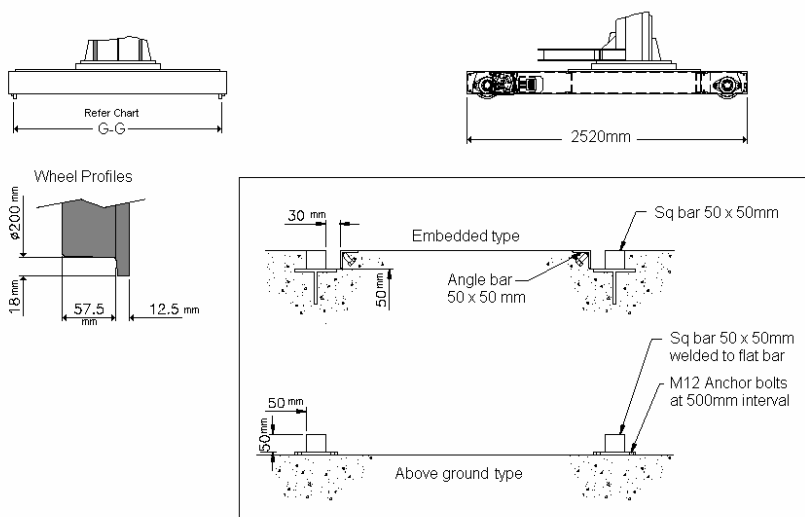

### MHD Type Travelcar Rails G-G in mm (250kg Payload)

V <sup>H</sup>	25	30	35	40
25	1650			
30				
35		2000		
40				

Notes:

V denotes Max.Under Boom Height (Vertical), in hundreds of mm. i.e. 20 = 2000mm

H denotes Effective Boom Travel (Horizontal), in hundreds of mm. i.e. 20 = 2000mm

..... [www.anplant.com](http://www.anplant.com) .....

MHD Series (Up to 4.0 x 4.0m) (C&B)

### Ordering Information Checklist

Equipment	Part Number	Description	
Column & Boom Manipulator	RM25/25MHD RM30/30MHD RM35/35MHD RM40/40MHD	2.5 x 2.5-metre Column & Boom 3 x 3-metre Column & Boom 3.5 x 3.5-metre Column & Boom 4.0 x 4.0-metre Column & Boom (Comes with standard fixed Base unless specified)	
Base	[Blank] TC- TCM-	Fixed base (Standard) Travel car Manual Travel car Motorized	Standard Optional Optional
Electrical Control	EA- SA-	Panel & 3-phase AC motor Panel, step-over & 3-phase AC motor	Standard Optional

### Welding System Accessories

<p><b>Option One</b></p> <ul style="list-style-type: none"> <li>• Lincoln NA3s Controller</li> <li>• K208A weld head</li> <li>• Drive roll kit</li> <li>• Wire reel</li> <li>• 600 amps nozzle</li> <li>• Cable kit Assemble</li> <li>• 10-Metre ground Cable with clamp</li> <li>• DC 1000 power source</li> </ul> <p><b>Optional:</b></p> <p style="padding-left: 40px;">Rotary Clamp 1000 amp</p>	<p><b>Option Two</b></p> <ul style="list-style-type: none"> <li>• Lincoln NA5 Controller</li> <li>• K346A weld head</li> <li>• Drive roll kit</li> <li>• Wire reel</li> <li>• 600 amps nozzle</li> <li>• Cable kit Assemble</li> <li>• 10 Metre ground Cable with clamp</li> <li>• DC 1000 power source</li> </ul> <p><b>Optional:</b></p> <p style="padding-left: 40px;">Rotary Clamp 1000 amp</p>	<p><b>Option Three</b></p> <ul style="list-style-type: none"> <li>• Miller HDC 1500 Controller</li> <li>• RAD Weld head</li> <li>• Flux hopper</li> <li>• Drive roll kit (Specify wire size)</li> <li>• Wire straightener</li> <li>• 600amps Nozzle</li> <li>• Wire reel</li> <li>• Cable kit assembly</li> <li>• 10 Metre ground Cable with clamp</li> <li>• Dimension 1000 power source</li> </ul> <p><b>Optional:</b></p> <p style="padding-left: 40px;">Rotary Clamp 100 amp</p>
--	---	--

..... [www.anplant.com](http://www.anplant.com) .....

MHD Series (Up to 4.0 x 4.0m) (C&B)

Specification for Manipulator

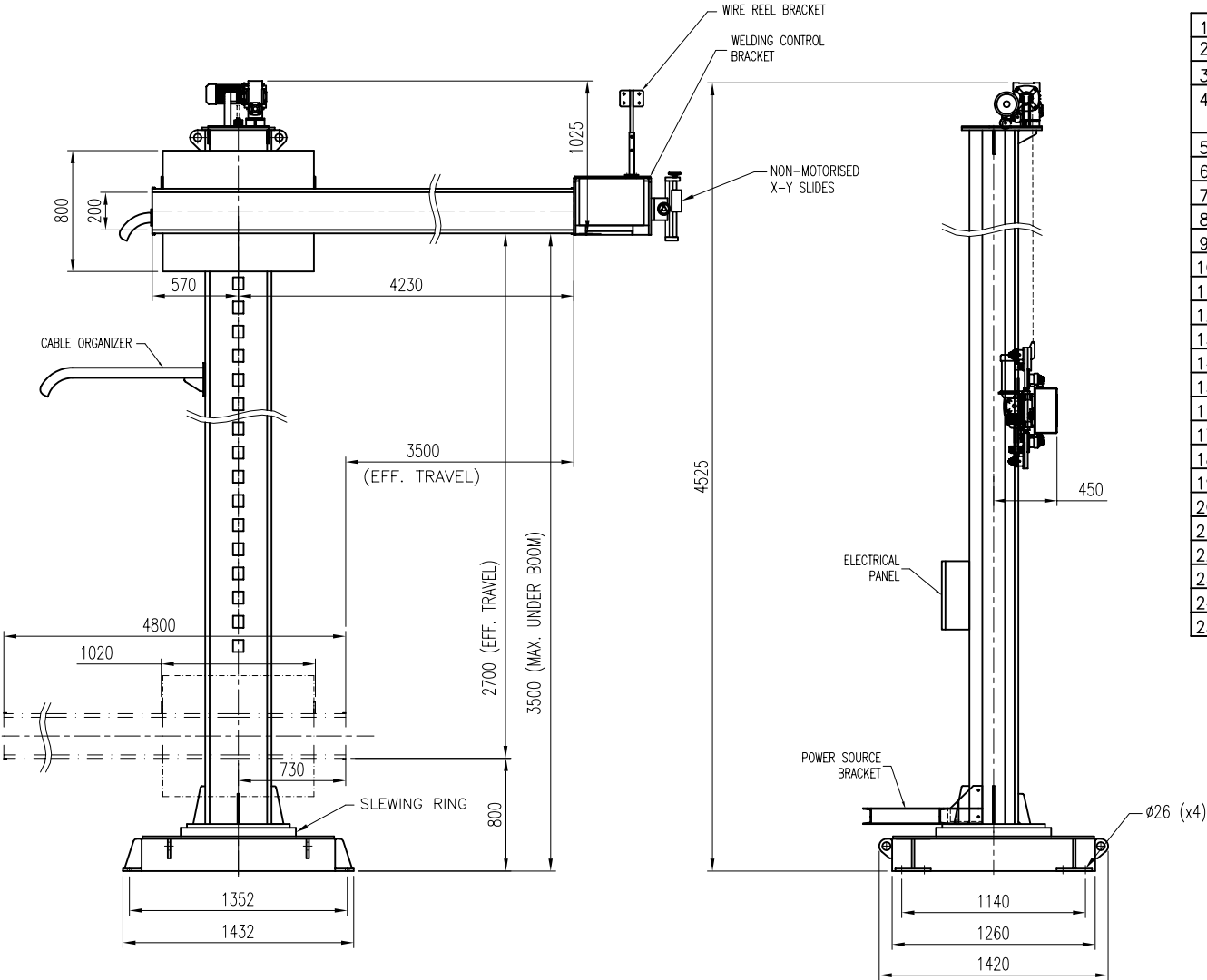

1	Model	RM3535MHD-EA
2	Max. Under Boom Height	3500mm
3	Effective Boom Travel	3500mm
4	Vertical Speed	754mm/min running at 50Hz 904mm/min running at 60Hz
5	Boom Speed	207~2074mm/min running at 5~50Hz
6	Travel Speed	449~4493mm/min running at 5~50Hz
7	Vertical Drive	AC 0.75kW c/w Brake
8	Boom Drive	AC 0.55kW c/w Force Cooling
9	Travelcar Drive	N.A.
10	Welding Control/Brand	T.B.A.
11	Welding Power Source/Brand	T.B.A.
12	Electrical Panel	Yes
13	Base Type	Fixed Base
14	Travelcar G-G	N.A.
15	Slewing Feature	Manual
16	Slewing Drive	N.A.
17	X-Y Slides (Optional)	Manual, 200mm Stroke
18	Flux Recovery (Optional)	No
19	Power Supply	380/400/415/440/480V-3P-50/60Hz
20	Control Voltage	24Vac
21	Control Means	Push Button Pendant c/w 6m Cable
22	Surface Preparation	Gritblast to SA2.5
23	Painting	2 coats Zinc Phosphate, 1 coat Polyurethane
24	Color	RAL5015 Blue
25	Qty	T.B.A.

ALL DIMENSIONS IN MM, UNLESS OTHERWISE SPECIFIED.

		PROJECT/MODEL :		RM3535MHD-EA
		CLIENT :		
DRAWN	NAME	DATE	DWG. NAME : MANIPULATOR GENERAL ARRANGEMENT	SCALE: N.T.S.
APPROVED	ROBIN.T	11-01-07		
			SHEET NO: 1 OF 1	
THE ORIGINAL AND ALL COPIES OF THIS DRAWING TOGETHER WITH THE COPYRIGHT THEREOF ARE THE SOLE PROPERTY OF R.P.E. PTE. LTD. SINGAPORE				

Specification for Manipulator

1	Model	RM3535MHD-TCM-EA-G1650
2	Max. Under Boom Height	3500mm
3	Effective Boom Travel	3500mm
4	Vertical Speed	754mm/min running at 50Hz 904mm/min running at 60Hz
5	Boom Speed	207~2074mm/min running at 5~50Hz
6	Travel Speed	449~4493mm/min running at 5~50Hz
7	Vertical Drive	AC 0.75kW c/w Brake
8	Boom Drive	AC 0.55kW c/w Force Cooling
9	Travelcar Drive	AC 0.55kW c/w Brake
10	Welding Control/Brand	Lincoln NA3
11	Welding Power Source/Brand	Lincoln DC 1000
12	Electrical Panel	Yes
13	Base Type	Motorised Travelcar
14	Travelcar G-G	Wheel G-G 1645mm for G-G 1650mm Rails
15	Slewing Feature	Manual, 360°
16	Slewing Drive	N.A.
17	X-Y Slides	Manual, 200mm Stroke
18	Flux Recovery	No
19	Power Supply	415V-3P-50Hz
20	Control Voltage	24Vac
21	Control Means	Push Button Pendant c/w 8m Cable
22	Surface Preparation	Gritblast to SA2.5
23	Painting	2 coats Zinc Phosphate, 1 coat Polyurethane
24	Color	RAL 3003 Red
25	Qty	1 unit

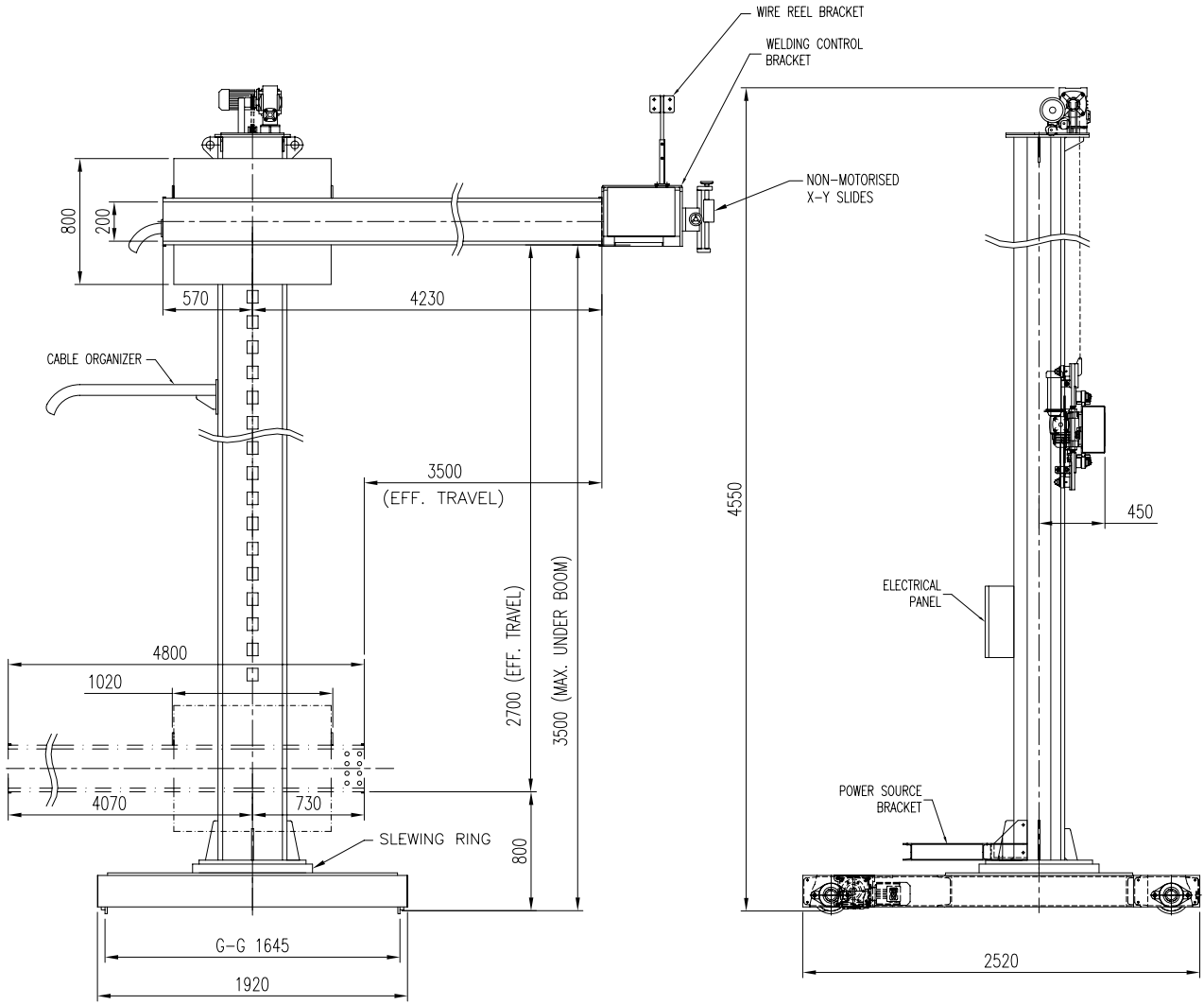

Wheel Profiles (For Reference)

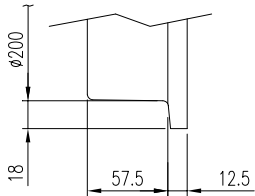

Recommended Rail Profiles (By Client)

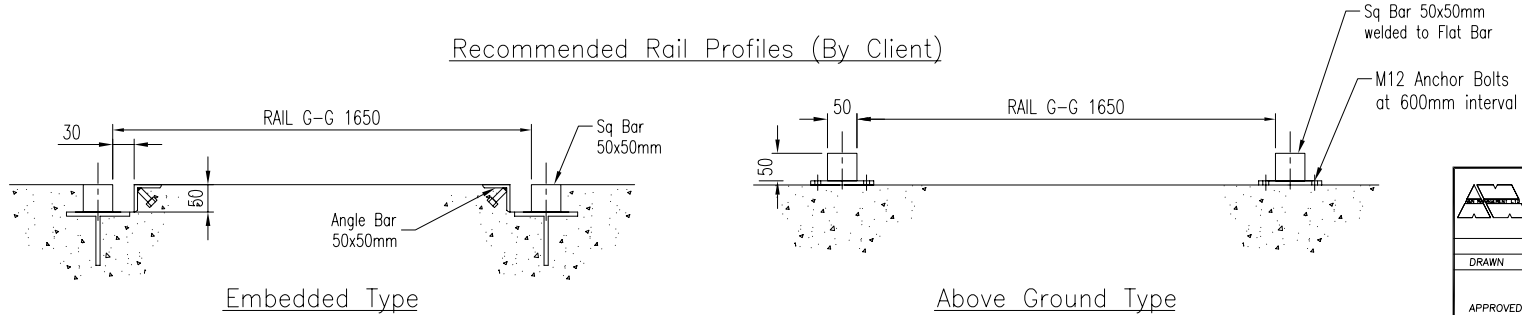

<b>A&amp;N PLANT</b> ROTATORS - COLUMN BEAMS - POSITIONERS			PROJECT/MODEL : RM3535MHD-TCM-EA-G1650	
DRAWN : Kris			DATE : 07-11-05	CLIENT : -
APPROVED :			DWG. NAME : MANIPULATOR GENERAL ARRANGEMENT	SCALE : N.T.S.
			DWG. NO. : SD-RM3535MHD-TCM-EA-G1650	REVISION : 0
				SHEET NO : 1 OF 1
THE ORIGINAL AND ALL COPIES OF THIS DRAWING TOGETHER WITH THE COPYRIGHT THEREOF ARE THE SOLE PROPERTY OF R.P.E. PTE. LTD. SINGAPORE				

ALL DIMENSIONS IN MM, UNLESS OTHERWISE SPECIFIED.